

# CONSTANTINOPLE

## THE 1994 SCIENCE FICTION CONVENTION

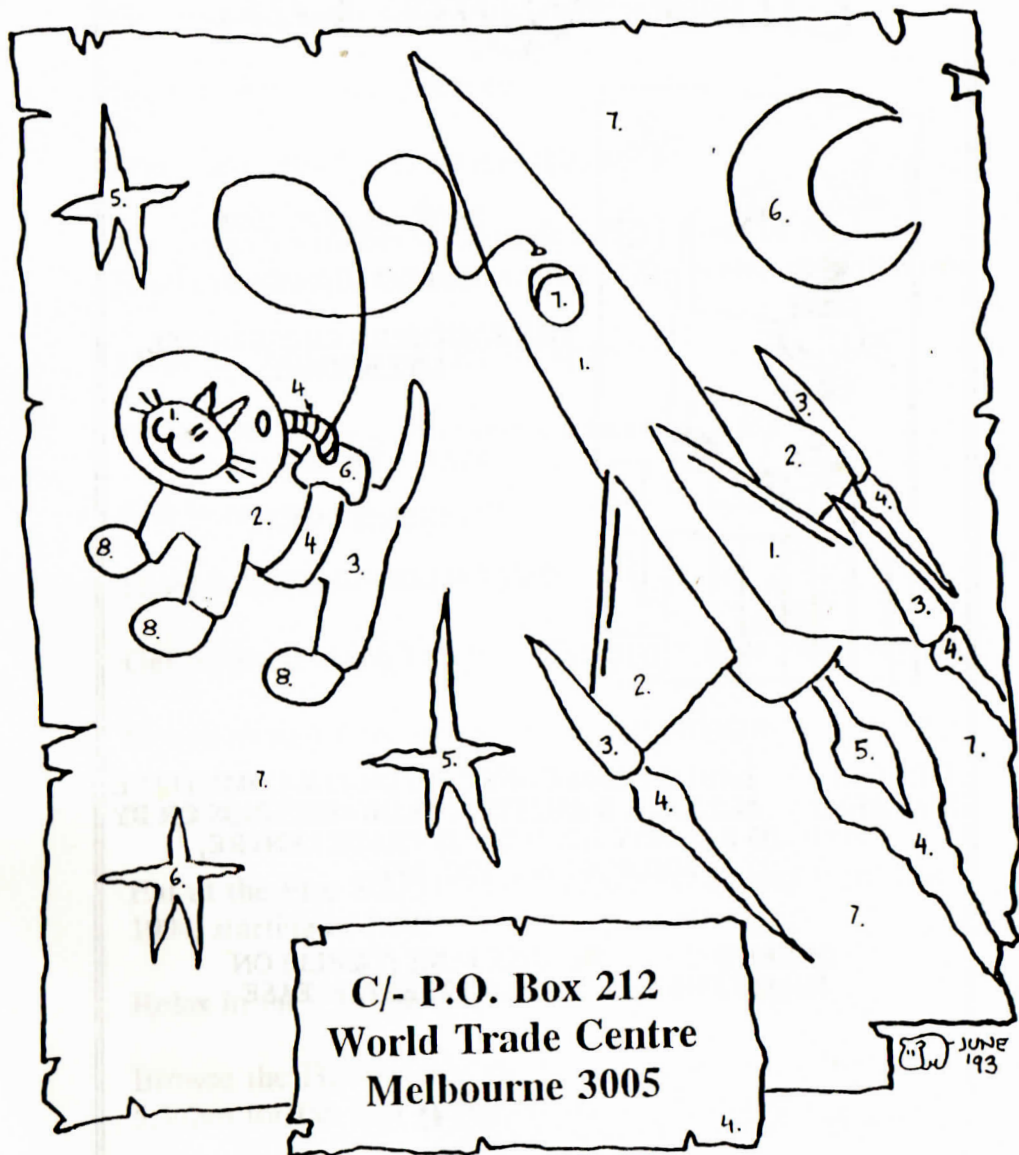

1. SKY BLUE  
2. LIGHT BLUE

3. DARK BLUE  
4. RED

5. ORANGE  
6. YELLOW

7. BLACK  
8. GREEN

3rd Annual Science Fiction Ball

# Cat's Night Out

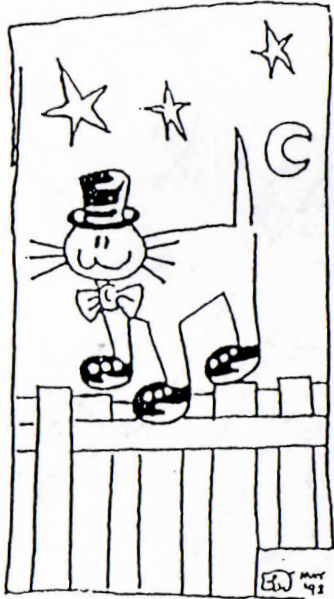

28TH AUGUST, 1993

7PM TO MIDNIGHT

THE SOUTHERN CROSS HOTEL,  
MELBOURNE

\$40.00 PER PERSON

3 COURSE MEAL

PAY ON CONSUMPTION BAR

TICKETS AVAILABLE FROM CONSTANTINOPLE COMMITTEE  
MEMBERS AT M.S.F.C. OR AUSTREK CLUB MEETINGS OR BY  
MAIL TO P.O. BOX 212, WORLD TRADE CENTRE,  
MELBOURNE, VIC. 3005

QUERIES CONTACT MISS JANE (TISELL) ON  
(03) 859 3110 BEFORE 10.00PM EST, PLEASE

Hosted by

**Constantinople**

*The National Convention in 1994*

## WHAT CAN YOU DO AT CONSTANTINOPLE?

You can attend any of the three streams of programming which will appeal to both media and literature SF fans.

Get an Autograph at the Autograph sessions.

Bid for items at the Auctions.

Watch the Panel sessions and discussions.

Go to lunch with fannish friends either at one of the Southern Cross eateries or nearby in the centre of Melbourne.

Listen to the Guest of Honour speeches.

Discuss the latest controversies with other fans.

Join in and play Silly games.

Hang out at a room party.

Get involved in the Freeform Cyberpunk Role Play Gaming.

Slouch along to one of the two Video programme streams.

Scope the First Release film preview.

Eat at the Five Star Dessert Banquet on Sunday April 2nd 1994, starting at 7.00pm. (More details later).

Relax in the Fan lounge with free tea and coffee.

Browse the Hucksters in the Omega room, open 10.00am to 5.30pm for the four days of CONSTANTINOPLE.

Sleep (Oh yeah, this is THE Natcon, remember!)

**WHATEVER YOU DO, WE HOPE YOU HAVE FUN!**

**ARE YOU FEELING COMPETITIVE?**

**Have you entered the SHORT STORY COMPETITION?**

**First Prize--\$300**

**Second Prize--\$150**

**Third Prize--\$50.**

The contest is sponsored by the Australian SF Foundation and is open to all writers, not just members of CONSTANTINOPLE.

The winning story will be the BEST Science Fiction story of not more than 3,000 words.

Entries are open now and close on the 31st of January 1994.

Please send your entries in to:

Constantinople  
Short Story Competition  
P.O. Box 212  
WORLD TRADE CENTRE  
Melbourne VICTORIA 3005.

Make sure your name and address is on the front page.

Constantinople reserves the one-time right to publish the winners in the convention programme book.

**NOMINATE 1993'S BEST OF THE BEST.**

**The A.S.F.M.A. Awards: The Australian Science Fiction Media Awards.**

Best Fan Writer:

Best Fan Artist:

Best Newsletter:

Best Fan Fiction zine:

Best Amateur Audio/Visual  
Production:

My name is:

My mailing address is:

Post this form to: CONSTANTINOPLE  
P.O. BOX 212  
WORLD TRADE CENTRE 3005.

Anyone active in Australian Fandom can nominate.

**NOMINATE 1993'S BEST OF THE BEST.**

**The DITMAR AWARDS: The Australian Science Fiction Achievement Awards for works by Australians.**

Best Long Fiction:

Best Short Fiction:

Best Professional Art Work:

Best Fan Writer:

Best Fanzine:

Best Fan Artist:

William Atheling jr. award for Criticism:

My name is:

My mailing address is:

Post this form to: **CONSTANTINOPLE, P.O. BOX 212  
WORLD TRADE CENTRE 3005.**

Anyone active in Australian Fandom can nominate.

**CONSTANTINOPLE**

ALL PURPOSE FORM

Membership

Number

**MEMBERSHIP DETAILS**

- Attending (until September 1, 1993)    **\$90**        *(Payable in instalments - see Finances)*
- Supporting    **\$20**
- Voting Only    **\$5**
- Child under 12 at April 1, 1994    **\$40**
- Child under 5 at April 1, 1994    **FREE**
- I am already a member

**FINANCES**

- I would like to pay by instalments
- Please find enclosed a cheque/money order

*Note: Please make cheques or money orders payable to **Constantinople***

**COMPETITIONS**

- I am interested in entering the:    Masquerade
- Art Show        Short Story Competition

**OTHER INFORMATION**

- I would like to help out at Constantinople
- What would you like to see at Constantinople? .....
- .....
- I would like huckstering information sent to me when it is available

---

---

## HOTEL INFORMATION

In order to secure your hotel booking, you will need to send the cost of **one night's accommodation** to *Constantinople*, who will reserve the room for you. Just give us the details:

I would like to book a room at the Southern Cross Hotel at \$100.00 per night (\*\*Triple rooms are \$130 per night):

Single  Double  Twin  Triple\*\*

I would like to book a room at the Chateau Melbourne Hotel at \$70.00 per night (\*\*Triple rooms are \$85.00 per night):

Single  Double  Twin  Triple\*\*\*

I will be taking the room for the following nights:

Thursday  Friday  Saturday  Sunday  Monday   
31 March 1 April 2 April 3 April 4 April

I will be sharing my room with: .....

---

---

## PERSONAL INFORMATION

Name: .....

Address: .....

City: ..... State: ..... Postcode: .....

---

---

Send your completed form to:

*Constantinople*  
PO Box 212  
World Trade Centre  
MELBOURNE VIC. 3005

If you have any queries, you can call the *Constantinople* Hotline (before 10.00pm EST, please) on:

**(03) 429 8354**

---

---

## SO YOU WANT TO STAY AT CONSTANTINOPLE?

The main convention hotel is The Southern Cross, 131 Exhibition Street, Melbourne 3000.

Constantinople has negotiated room rates for convention members who want to stay at either at the Southern Cross or nearby at the Chateau Melbourne.

Accommodation at the Southern Cross costs convention members \$100 per night for a single, double or twin room. A triple room is \$130 per night.

Car parking underneath the hotel is free for members who stay at the Southern Cross. You get one car space per room.

We have arranged other accommodation at the Chateau Melbourne, 131 Lonsdale Street, Melbourne 3000.

It will cost CONSTANTINOPLE members \$70 per night, single, double or twin room. A triple room will cost \$85 per night.

Please book your rooms by sending in the membership form to Constantinople.

## PARKING YOUR CAR.

If you are not staying at Constantinople, but are coming by car, you may be interested in our \$4.00 per entry deal with Duke Car Parking in the Bourke Plaza Car Park, 110 Bourke Street, Melbourne. The discount rate applies from Thursday 31st of March to Monday April 4th 1994.

We will stamp your parking ticket with our Constantinople stamp so you get the \$4.00 per entry or \$16.00 leave your car there for the weekend rate. Ask at Registration about Duke parking.

## "THE WORLDS FAIR 2500 A.D."

It is the year 2500; the Earth has been ravaged by war and famine and the Ozone layer now covers only two-thirds or the Earth's surface. Or does it?

It is the year 2500; war and famine have been wiped from the Earth and the Ozone layer has been fully restored!

What type of clothing will be worn in the 24th century? How do you think people will dress and act? Will it be like Star Trek or Blakes Seven?

Will the Federation govern our planet? Will it be a giant corporation, like in Blade Runner or DAAS Kaptial? Perhaps Shitzu Tonka will rule the world!

The theme for CONSTANTINOPLE's Masquerade is "The World's Fair 2500 A.D." It is open to all attending convention members. There will be a large stage and professional lighting and sound equipment will be provided.

THE WORLD'S FAIR 2500 A.D. starts at 8.00 pm, Saturday 2nd April 1994 in the Australis Ballroom at the Southern Cross.

## "VISIONS OF A FUTURE BLEAK!"

Are you thinking of entering work in the art show? During CONSTANTINOPLE the Kapa room at the Southern Cross will house the convention's art show.

There will be professional and fannish artwork divisions and also a special prize for the piece of artwork which best reflects the work of William Gibson.

Art show works can be put in the special Art Auction. Constantinople will take a 10% commission on sales.

"She held out her hands, palms up, the white fingers slightly spread and with a barely audible click then double edged scalpel blades slid from their housing beneath the burgandy nails. She smiled, the nails slowly withdrew....."

*Neuromancer*, by William Gibson.

"The sky above the port was the colour of a Television tuned to a dead channel."

*Neuromancer*, by William Gibson.

W

I

L

L

I

A

M

The creator of 'Cyberpunk'

is coming to

**CONSTANTINOPLE**

Easter '94

G

I

B

S

O

N

"You could say that Cyberpunk is postmodern science fiction. It's a lot more postmodern than the old science fiction was..."

William Gibson in *Cyberpunk* the documentary.

*Neuromancer*, winner of the Hugo, Nebula and Phillip K Dick awards.

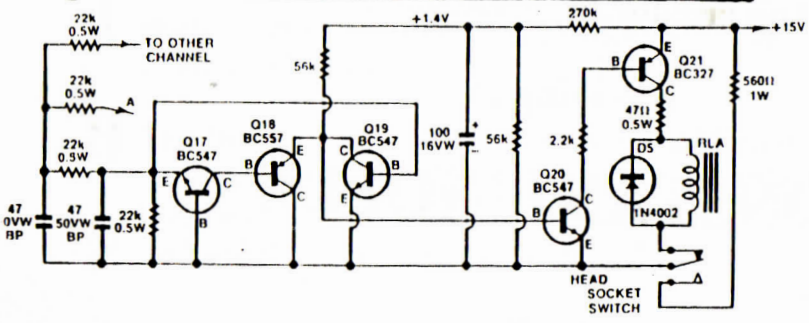
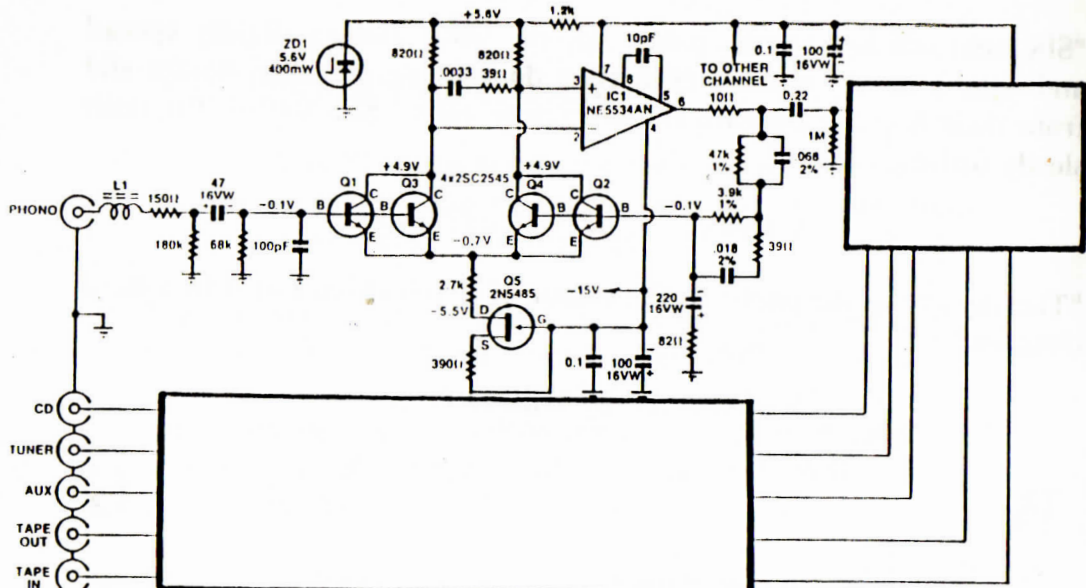

# CONSTANTINOPLE 1994

## PROGRESS REPORT No.6, JULY 1993

PO Box 212  
 World Trade Centre  
 Melbourne 3005  
 AUSTRALIA

